

Code:

ALG-MRW240NW-WM

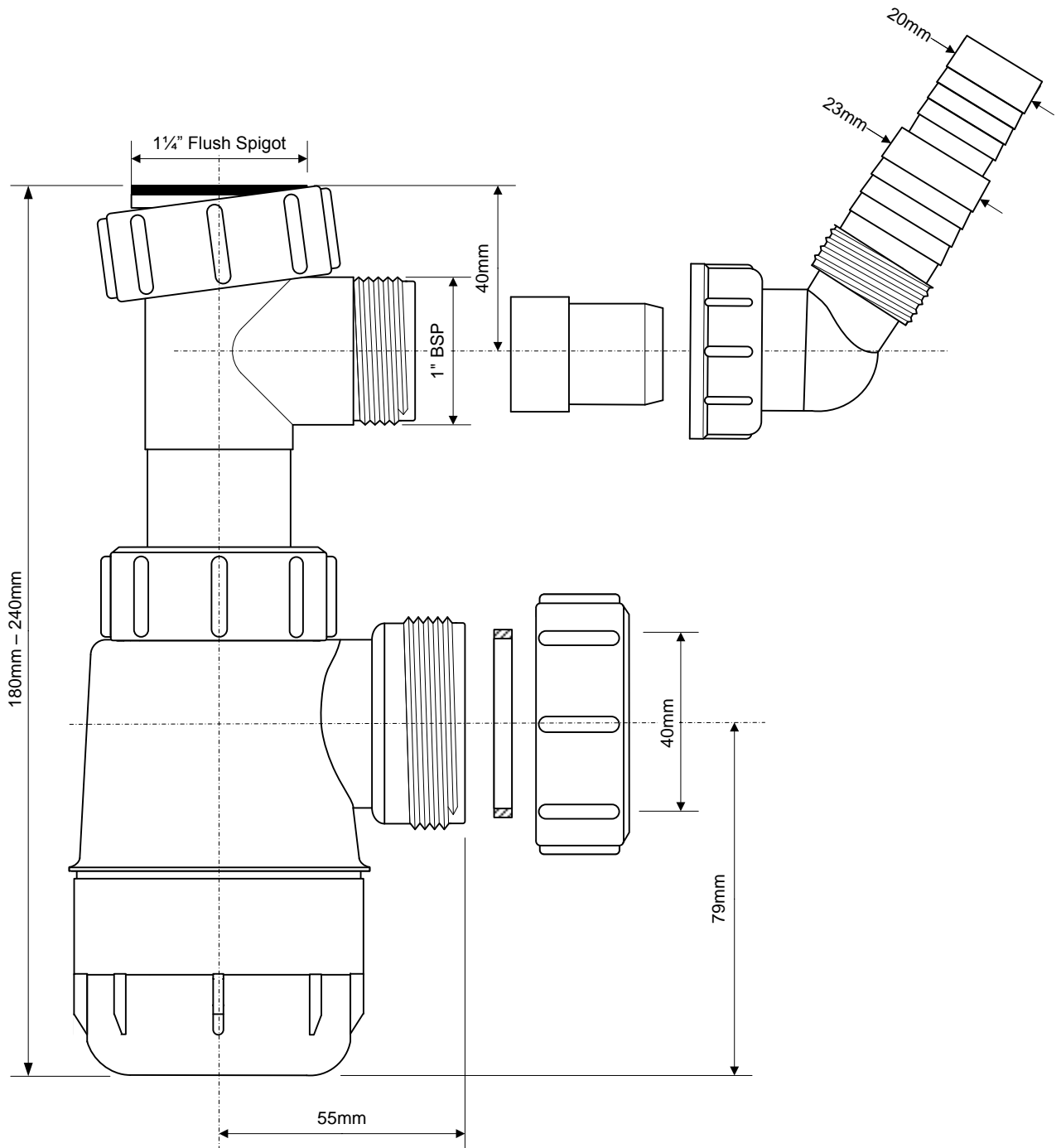

©

McALPINE

Drawing verified
correct as of:

03.05.17
T.C.

DRAWN BY

TC

SCALE

1: 1.4

REVISED

FILENAME

ALG-MRW240NW-WM.VSD

DATE

03.05.17

Code:

ALG-MRW240NW-WM

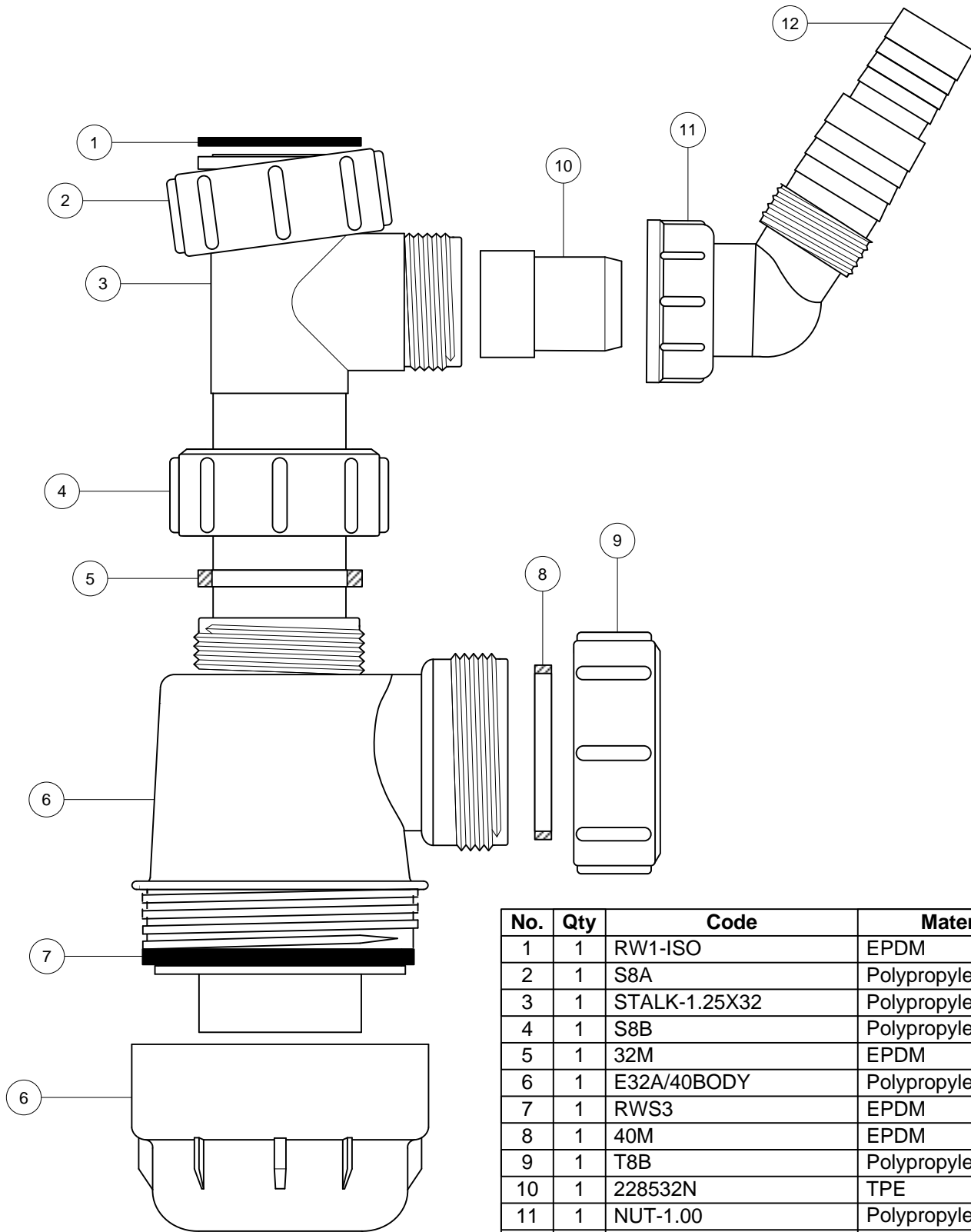

No.	Qty	Code	Material
1	1	RW1-ISO	EPDM
2	1	S8A	Polypropylene
3	1	STALK-1.25X32	Polypropylene
4	1	S8B	Polypropylene
5	1	32M	EPDM
6	1	E32A/40BODY	Polypropylene
7	1	RWS3	EPDM
8	1	40M	EPDM
9	1	T8B	Polypropylene
10	1	228532N	TPE
11	1	NUT-1.00	Polypropylene
12	1	MA15BODY	Polypropylene

©

McALPINE

Drawing verified
correct as of:

03.05.17
T.C.

DRAWN BY TC
SCALE 1: 1.4

REVISED

FILENAME ALG-MRW240NW-WM.VSD
DATE 03.05.17